

# Powerbolt 3

## Installation and User Guide

Weiser Technical Support | 1-800-501-9471 | www.weiserlock.com

**Required tools**

Batteries Ruler Screwdrivers

**Additional Tools (depending on application)**

Hammer Wood block

3D instructions available on

SCAN FOR BILT 3D INSTRUCTIONS

POWERED BY BILT INTELLIGENT INSTRUCTIONS™

**Parts in the box**

<b>Latch</b>	<b>Interior Assembly</b>	<b>Exterior Assembly</b>
<b>Adapter Ring</b>	<b>For Latch / Strike</b>	<b>For Lock</b>
	<b>Strike</b>	<b>SmartKey Tool</b> 52502
<b>Collar</b>	<b>53648</b>	<b>52367</b>
<b>Keys</b>		

### 1 Prepare the door and check dimensions

If drilling a new door, use the supplied template and the complete door drilling instructions available at [www.kwikset.com/doorprep](http://www.kwikset.com/doorprep).

**A** Measure to confirm that the hole in the door is either 54 mm (2-1/8 in) or 38 mm (1-1/2 in).

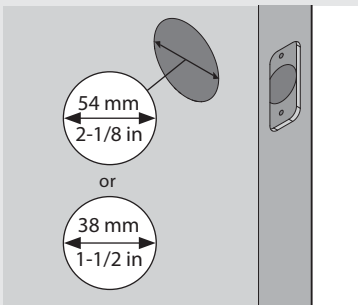

Note: Additional door preparation may be required for doors with 38 mm (1-1/2 in) holes.

**B** Measure to confirm that the backset is either 60 or 70 mm (2-3/8 or 2-3/4 in).

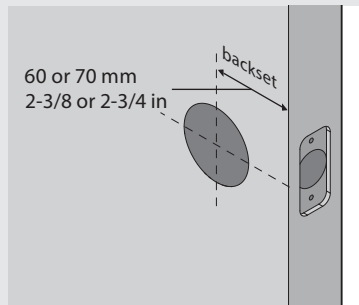

**C** Measure to confirm that the hole in the door edge is 25 mm (1 in).

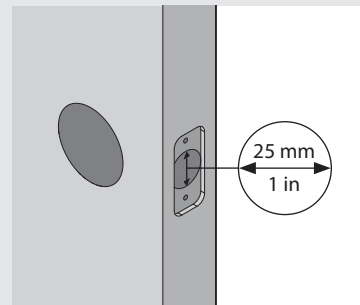

**D** Measure to confirm that the door is between 35 mm and 44 mm (1-3/8 and 1-3/4 in) thick.

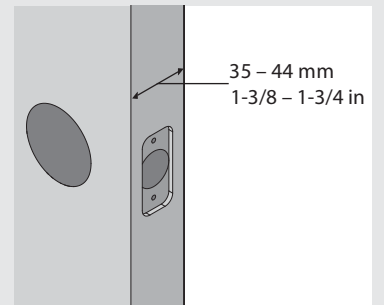

Note: Please contact customer service if door thickness exceeds 44 mm (1-3/4 in) for a thick door kit.

### 2 Install the latch and strike

For Latch / Strike Bag

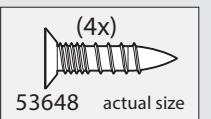

**A** Hold the latch in front of the door hole, with the latch face flush against the door edge.

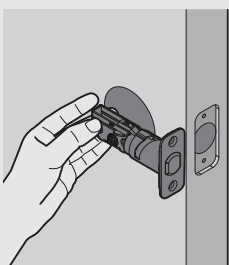

Is the rectangular shaped hole centered in the door hole?

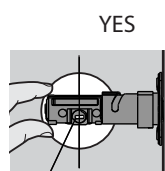

**YES**  
Rectangular shaped hole  
No adjustment is required. Proceed to next step.

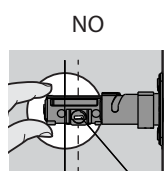

**NO**  
Rectangular shaped hole  
Rotate latch face as shown to extend latch.

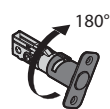

**B** Is the door edge chiseled?

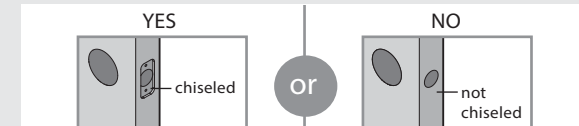

**YES**  
chiseled  
Install latch in door with supplied screws.

**NO**  
not chiseled  
Use a flathead screwdriver to remove latch face. Once removed, grip the latch with one hand and with the other hand twist collar off. Install drive-in collar.

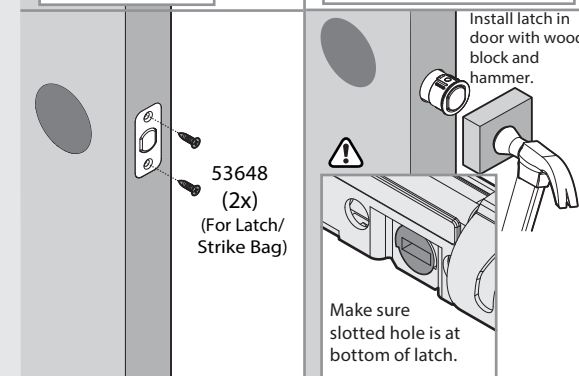
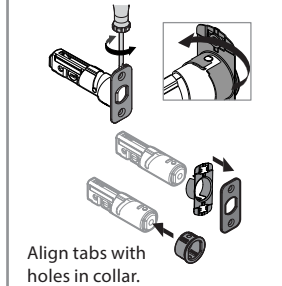
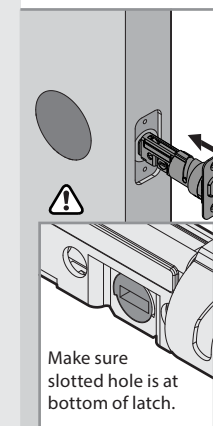

**C** Install strike on the door frame.

⚠ Make sure the hole in the door frame is drilled a minimum of 25 mm (1 in) deep.

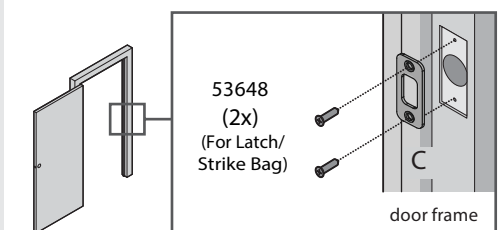

**D** ⚠ IMPORTANT: Make sure the latch bolt is fully retracted (in the unlocked position).

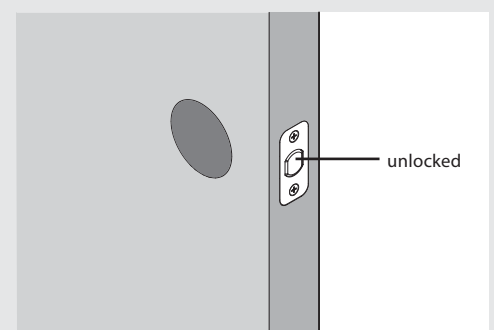

### 3 Install the exterior keypad

For Lock Bag

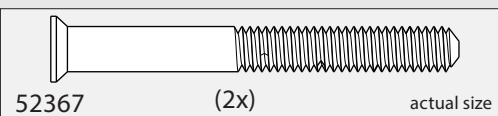

A What is the diameter of the hole in the door?

<p>Diameter is 54 mm (2-1/8 in)</p> <p>Adapter ring is required for installation.</p>	or	<p>Diameter is 38 mm (1-1/2 in)</p> <p>Adapter ring is not needed for installation.</p>
---	----	---

B Locate screws for step 3C and keep them within reach.

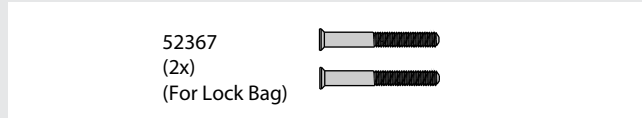

C Install exterior keypad and mounting plate.

<p>a</p>	<p>b</p>
<p>c</p>	<p>d</p>

### 4 Install the interior assembly

For Lock Bag

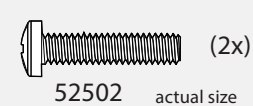

A Remove interior cover from interior assembly.

<p>a</p>	<p>b</p>
<p>c</p>	<p>d</p>

B Secure the interior assembly onto the mounting plate.

<p>a</p>	<p>b</p>
<p>c</p>	<p>d</p>

### 5 Install the batteries in the interior assembly

A Install 4 AA batteries in interior assembly

Ensure your door is open while installing batteries. Ensure the interior cover is off to install batteries. Note: Batteries are not included

Ensure correct polarity. For best results, use new, non-rechargeable alkaline batteries only.

B Install interior cover for the interior assembly.

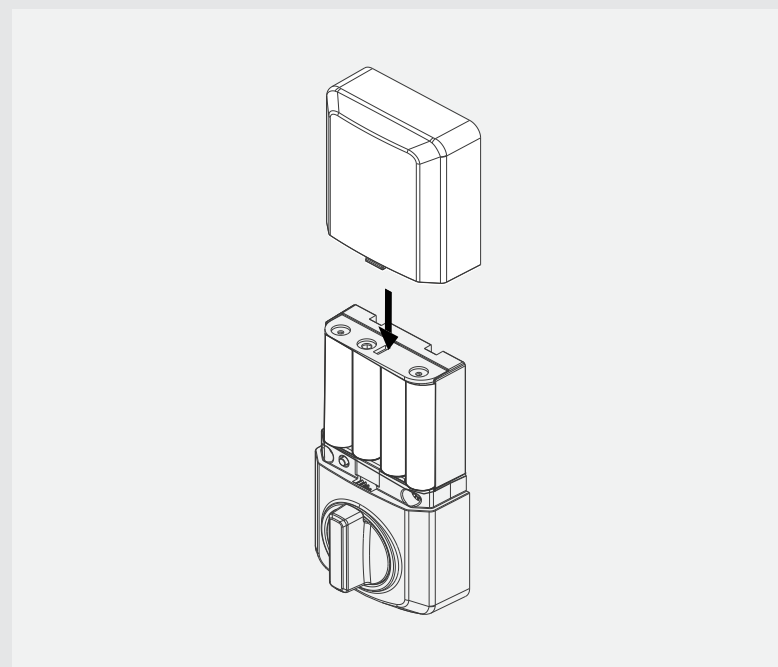

## 6 Add user codes (25 max)

**A** Make sure the interior cover is off. Press the Program button once.

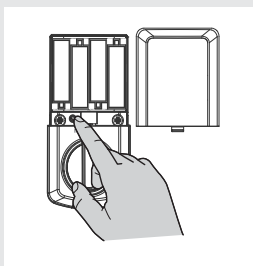

**B** Press number 1.

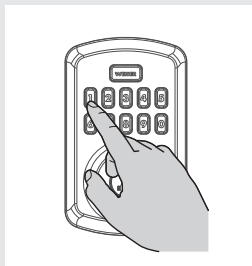

**C** Press Weiser logo once.

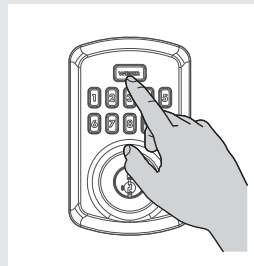

**D** Enter user code. A total of 25 user codes may be programmed. User codes should be 4 to 8 digits in length.

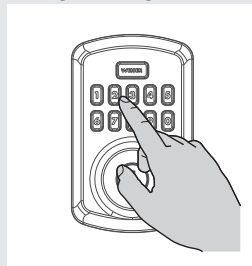

**E** Press Weiser logo once.

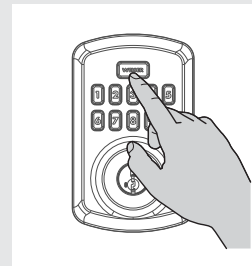

During programming, if no button is pressed within 5 seconds, the system will time out and you will need to restart the procedure

⚠ For security reasons, the first 4 digits of each User Code must be unique. For example, you are unable to program a user code 1-2-3-4-5 as well as user code 1-2-3-4-6.

Note: After the first User Code is created, the latch bolt will automatically retract and extend to learn the locking and unlocking direction of the door. The Kwikset logo will indicate success or failure. GREEN: Success RED: Unsuccessful

## 7 Test the lock (review normal operation)

⚠ Before you can lock and unlock the door, a User Code must be created. Refer to Step 6 for instructions how to create a User Code. Confirm that the code(s) added in previous step can unlock the door.

**A** To lock your door, press the Weiser logo button. The lock will beep twice and the Weiser logo button will flash amber as the deadbolt extends.

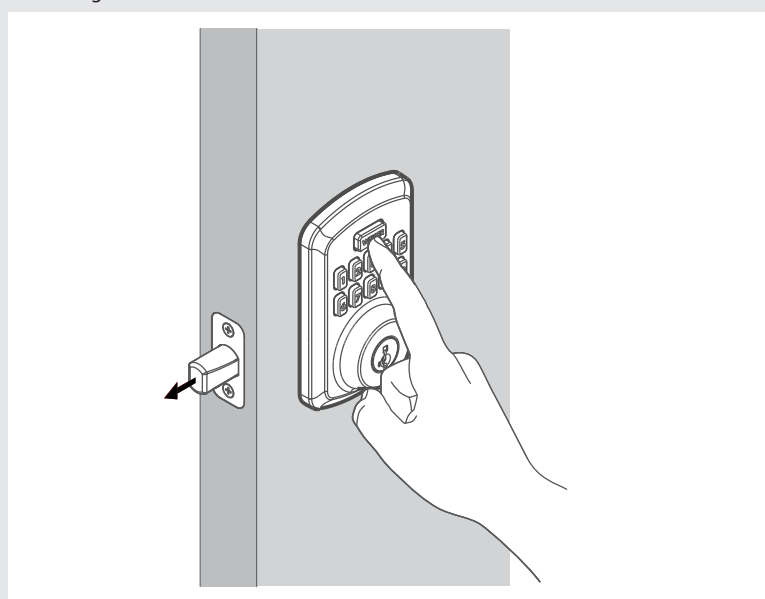

**B** To unlock your door, enter the user code. The lock will beep twice and the Weiser logo button will flash green as the deadbolt retracts.

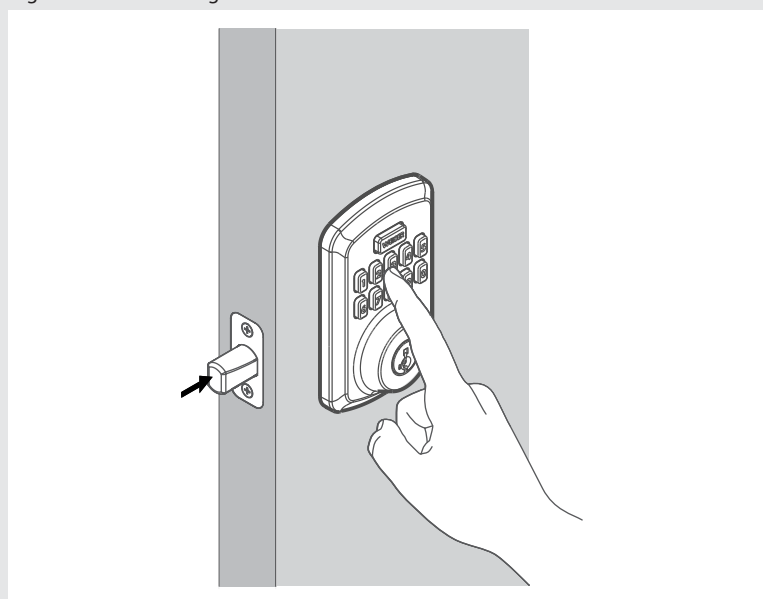

## 8 Adding a One-time User Code

1. Remove interior cover. Press programming button.

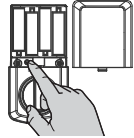

2. Press number 7.



3. Press the Weiser logo button.



4. Enter the one time user code.



5. Press the Weiser logo button.



Up to 5 One-time User Codes can be saved. One-time User Codes should be 4 to 8 digits in length. The One-Time User Code will be deleted automatically after it is used. The same One-Time User Code can be created again after it's used.

## 9 Delete a Single User Code

1. Remove interior cover. Press programming button.

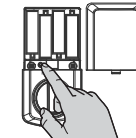

2. Press number 2.



3. Press the Weiser logo button.



4. Enter the user code you want to delete.



5. Press the Weiser logo button.



6. Enter the user code being deleted again.



7. Press the Weiser logo button again.



If unsuccessful: Make sure you entered the same user code in steps 4 and 6.

⚠ Test code while the door is open. Test the User Code to make sure it no longer unlocks the door.

If a button is not pressed within 5 seconds, the system will time out, and you will need to restart the procedure.

## 10 Delete ALL User Codes

Note: Keypad locking function will be disabled when User Codes are deleted. The lock can only be operated manually by a key during this time.

1. Remove interior cover. Press programming button.

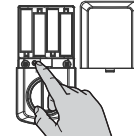

2. Press number 4.



3. Press the Weiser logo button.



4. Press number 4.



5. Press the Weiser logo button.

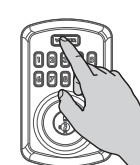

## 11 Enable/ Disable Audio

1. Remove interior cover. Press programming button.

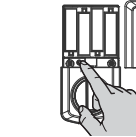

2. Press number 5.



3. Press the Weiser logo button.



Note: LED status indicator will still function once audio is disabled. Repeat the programming steps to enable the audio.

## 12 Enable/ Disable User Codes

Note: When all User Codes are disabled, all electronic functions will be disabled as well. The door must be locked or unlocked manually with the key. Repeat the programming steps to enable the User Codes.

1. Remove interior cover. Press programming button.

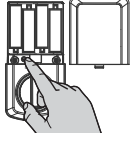

2. Press number 6.



3. Press the Weiser logo button.



## 13 Enable/ Disable Auto-Lock

1. Remove interior cover. Press programming button.

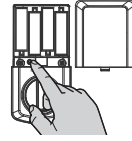

2. Press number 9.



3. Press the Weiser logo button.



Repeat the programming steps to disable the auto-lock.

## 14 Change Auto-Lock Time Delay

1. Remove interior cover. Press programming button.

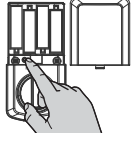

2. Press number 8.



3. Press the Weiser logo button.

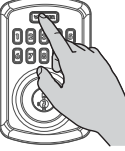

4. Choose and press button for delay.

- |              |              |
|--------------|--------------|
| 1 30 seconds | 4 5 minutes  |
| 2 1 minute   | 5 10 minutes |
| 3 3 minutes  |              |

5. Press the Weiser logo button.



## 15 Door Rehanding

1. Remove interior cover. Press programming button.

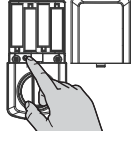

2. Press number 0.



3. Press the Weiser logo button.

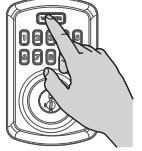

The latch bolt will extend and retract to learn the orientation of the door.

Note: Perform this process for the lock to learn the locking and unlocking direction of the door. This feature is used for the lock to learn the orientation of your door (left- or right-handed). If stuck/jammed bolt error continues to occur after performing this step, please make sure there is no obstruction from strike or door jamb to prevent the bolt from extending.

## 16 Factory Reset

⚠ Note: Lock must be in an unlocked position to factory reset.

1. Remove interior cover. PRESS and HOLD programming button for 15 seconds.

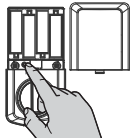

2. The lock will have a long beep.

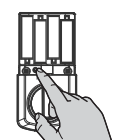

3. Press programming button once more.

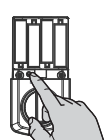

A factory reset will delete all User Codes and change all programming to factory settings. At this time, the lock can only be locked or unlocked manually with the key.

## 17 Add/ Change Programming Code

1. Remove interior cover. Press programming button.

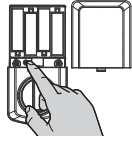

2. Press number 3.



3. Press the Weiser logo button.



4. Enter Programming Code.



5. Press the Weiser logo button.



Enable/ Disable Programming Code:

Optional: A Programming Code enables you to make programming changes without needing to access the Programming Button. This is ideal for landlords to program the lock without access to the interior programming button.

Note: Once Programming Code is enabled, the Programming Button is disabled and can only be used to factory reset the lock.

One Programming Code between 4 to 8 digits can be saved and cannot be the same as any User Code and cannot be used as a User Code to unlock the lock.

To program the lock with Programming Code:

Programming Code → [Weiser Logo] → Follow the programming steps WITHOUT PRESSING the PROGRAMMING BUTTON

To disable Programming Code:

Programming Code → [Weiser Logo] → [3] → [Weiser Logo] → Programming Code → [Weiser Logo]

### SmartKey Re-Keying

Re-key the lock to work with your existing kw1 key. See the supplied SmartKey Re-key instructions for more information.

Note: If Auto-Lock is enabled remove batteries before re-keying your lock.

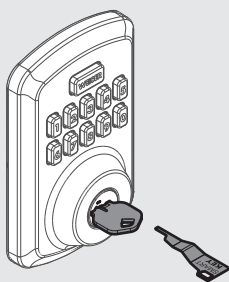

### Powerbolt at a Glance

Exterior

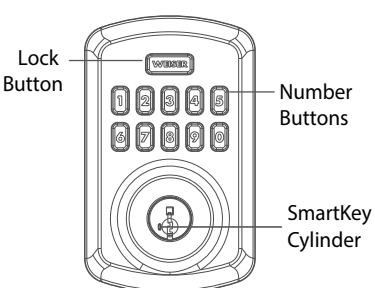

Interior

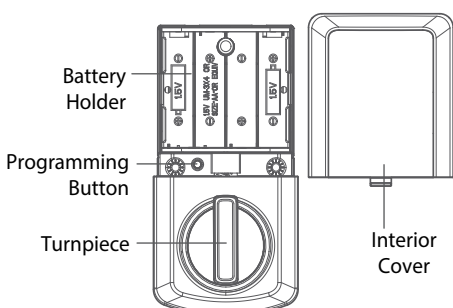

### System Alerts

Action	Lights	Sounds	Troubleshoot
Successful Unlock	Flashes GREEN x2	2 beeps	
Successful Lock	Flashes AMBER x2	2 beeps	
Low battery	Flashes RED x10	10 beeps	Install fresh new batteries
Incorrect User Code	Flashes RED x 3	3 beeps	Check code, and retry
Exceed 3 incorrect User Code attempts	Flashes RED x15	15 beeps	Wait 1 minute, check code, and retry
Stuck/Jammed bolt	Alternate RED/ WHITE Flash x5	5 beeps	Clear jam and try again
Factory Reset Successful	Flashes GREEN x1	1 beep	
Factory Reset Unsuccessful	Flashes RED x3	3 beeps	Retry factory reset steps. Make sure to press the Programming Button one more time within 10 seconds after the long beep.
Programming Successful	Flashes GREEN x1	1 beep	
Programming Unsuccessful	Flashes RED x3	3 beeps	Review Programming steps

### Important Safeguards

1. Read all instructions in their entirety.
2. Familiarize yourself with all warning and caution statements.
3. Remind all family members of safety precautions.
4. Always have access to your lock's standard key.
5. If using the Auto-Lock features, make sure you have your standard key with you to prevent locking yourself out.
6. Familiarize yourself with the system alerts.
7. Replace low batteries immediately.
8. Dispose of used batteries according to local laws and regulations.

⚠ WARNING:

This Manufacturer advises that no lock can provide complete security by itself. This lock may be defeated by forcible or technical means, or evaded by entry elsewhere on the property. No lock can substitute for caution, awareness of your environment, and common sense. Builder's hardware is available in multiple performance grades to suit the application. In order to enhance security and reduce risk, you should consult a qualified locksmith or other security professional.

⚠ CAUTION:

Prevent unauthorized entry. Since anyone with access to the back panel can change the User Codes, you must restrict access to the back panel and routinely check the User Codes to ensure they have not been altered without your knowledge. The use of a programming code can help protect your system's settings.